



# 8041A/8641A/8741A UNIVERSAL PERIPHERAL INTERFACE 8-BIT MICROCOMPUTER

- 8-Bit CPU plus ROM, RAM, I/O, Timer and Clock in a Single Package
  - One 8-Bit Status and Two Data Registers for Asynchronous Slave-to-Master Interface
  - DMA, Interrupt, or Polled Operation Supported
  - 1024 × 8 ROM/EPROM, 64 × 8 RAM, 8-Bit Timer/Counter, 18 Programmable I/O Pins
- Fully Compatible with MCS-48™, MCS-80™, MCS-85™, and MCS-86™ Microprocessor Families
  - Interchangeable ROM and EPROM Versions
  - 3.6 MHz 8741A-8 Available
  - Expandable I/O
  - RAM Power-Down Capability
  - Over 90 Instructions: 70% Single Byte
  - Single 5V Supply

The Intel® 8041A/8741A is a general purpose, programmable interface device designed for use with a variety of 8-bit microprocessor systems. It contains a low cost microcomputer with program memory, data memory, 8-bit CPU, I/O ports, timer/counter, and clock in a single 40-pin package. Interface registers are included to enable the UPI device to function as a peripheral controller in MCS-48™, MCS-80™, MCS-85™, MCS-86™, and other 8-bit systems.

The UPI-41A™ has 1K words of program memory and 64 words of data memory on-chip. To allow full user flexibility the program memory is available as ROM in the 8041A version or as UV-erasable EPROM in the 8741A version. The 8741A and the 8041A are fully pin compatible for easy transition from prototype to production level designs. The 8641A is a one-time programmable (at the factory) 8741A which can be ordered as the first 25 pieces of a new 8041A order. The substitution of 8641A's for 8041A's allows for very fast turnaround for initial code verification and evaluation results.

The device has two 8-bit, TTL compatible I/O ports and two test inputs. Individual port lines can function as either inputs or outputs under software control. I/O can be expanded with the 8243 device which is directly compatible and has 16 I/O lines. An 8-bit programmable timer/counter is included in the UPI device for generating timing sequences or counting external inputs. Additional UPI features include: single 5V supply, low power standby mode (in the 8041A), single-step mode for debug (in the 8741A), and dual working register banks.

Because it's a complete microcomputer, the UPI provides more flexibility for the designer than conventional LSI interface devices. It is designed to be an efficient controller as well as an arithmetic processor. Applications include keyboard scanning, printer control, display multiplexing and similar functions which involve interfacing peripheral devices to microprocessor systems.

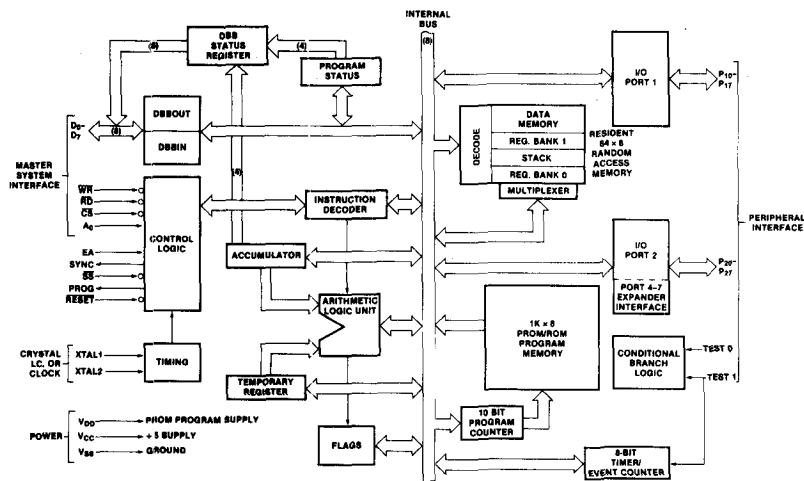

Figure 1. Block Diagram

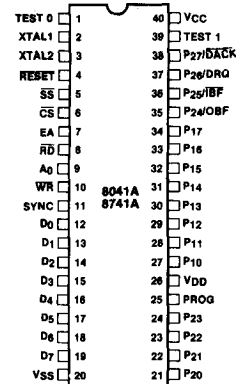

Figure 2. Pin Configuration

Table 1. Pin Description

Symbol	Pin No.	Type	Name and Function
TEST 0, TEST 1	1 39	I	<p><b>Test Inputs:</b> Input pins which can be directly tested using conditional branch instructions.</p> <p><b>Frequency Reference:</b> TEST 1 (<math>T_1</math>) also functions as the event timer input (under software control). TEST 0 (<math>T_0</math>) is used during PROM programming and verification in the 8741A.</p>
XTAL 1, XTAL 2	2 3	I	<p><b>Inputs:</b> Inputs for a crystal, LC or an external timing signal to determine the internal oscillator frequency.</p>
RESET	4	I	<p><b>Reset:</b> Input used to reset status flip-flops and to set the program counter to zero.</p> <p>RESET is also used during PROM programming and verification.</p>
SS	5	I	<p><b>Single Step:</b> Single step input used in the 8741A in conjunction with the SYNC output to step the program through each instruction.</p>
CS	6	I	<p><b>Chip Select:</b> Chip select input used to select one UPI-41A microcomputer out of several connected to a common data bus.</p>
EA	7	I	<p><b>External Access:</b> External access input which allows emulation, testing and PROM/ROM verification. This pin should be tied low if unused.</p>
RD	8	I	<p><b>Read:</b> I/O read input which enables the master CPU to read data and status words from the OUTPUT DATA BUS BUFFER or status register.</p>
A <sub>0</sub>	9	I	<p><b>Command/Data Select:</b> Address input used by the master processor to indicate whether byte transfer is data (<math>A_0=0</math>) or command (<math>A_0=1</math>).</p>
WR	10	I	<p><b>Write:</b> I/O write input which enables the master CPU to write data and command words to the UPI-41A INPUT DATA BUS BUFFER.</p>

Symbol	Pin No.	Type	Name and Function
SYNC	11	O	<p><b>Output Clock:</b> Output signal which occurs once per UPI-41A instruction cycle. SYNC can be used as a strobe for external circuitry; it is also used to synchronize single step operation.</p>
D <sub>0</sub> -D <sub>7</sub> (BUS)	12-19	I/O	<p><b>Data Bus:</b> Three-state, bidirectional DATA BUS BUFFER lines used to interface the UPI-41A microcomputer to an 8-bit master system data bus.</p>
P <sub>10</sub> -P <sub>17</sub>	27-34	I/O	<p><b>Port 1:</b> 8-bit, PORT 1 quasi-bidirectional I/O lines.</p>
P <sub>20</sub> -P <sub>27</sub>	21-24 35-38	I/O	<p><b>Port 2:</b> 8-bit, PORT 2 quasi-bidirectional I/O lines. The lower 4 bits (P<sub>20</sub>-P<sub>23</sub>) interface directly to the 8243 I/O expander device and contain address and data information during PORT 4-7 access. The upper 4 bits (P<sub>24</sub>-P<sub>27</sub>) can be programmed to provide interrupt Request and DMA Handshake capability. Software control can configure P<sub>24</sub> as Output Buffer Full (OBF) interrupt, P<sub>25</sub> as Input Buffer Full (IBF) interrupt, P<sub>26</sub> as DMA Request (DRQ), and P<sub>27</sub> as DMA ACKnowledge (DACK).</p>
PROG	25	I/O	<p><b>Program:</b> Multifunction pin used as the program pulse input during PROM programming.</p> <p>During I/O expander access the PROG pin acts as an address/data strobe to the 8243. This pin should be tied high if unused.</p>
V <sub>CC</sub>	40		<p><b>Power:</b> +5V main power supply pin.</p>
V <sub>DD</sub>	26		<p><b>Power:</b> +5V during normal operation. +25V during programming operation. Low power standby pin in ROM version.</p>
V <sub>SS</sub>	20		<p><b>Ground:</b> Circuit ground potential.</p>

## UPI-41A™ FEATURES AND ENHANCEMENTS

- Two Data Bus Buffers, one for input and one for output. This allows a much cleaner Master/Slave protocol.

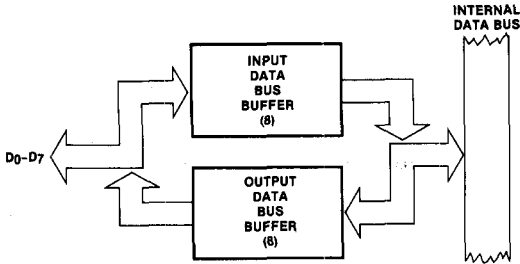

- 8 Bits of Status

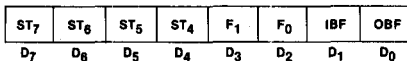

ST<sub>4</sub>-ST<sub>7</sub> are user definable status bits. These bits are defined by the "MOV STS, A" single byte, single cycle instruction. Bits 4-7 of the accumulator are moved to bits 4-7 of the status register. Bits 0-3 of the status register are not affected.

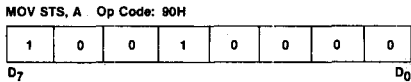

- $\overline{RD}$  and  $\overline{WR}$  are edge triggered. IBF, OBF, F<sub>1</sub> and INT change internally after the trailing edge of  $\overline{RD}$  or  $\overline{WR}$ .



- P<sub>24</sub> and P<sub>25</sub> are port pins or Buffer Flag pins which can be used to interrupt a master processor. These pins default to port pins on Reset.

If the "EN FLAGS" instruction has been executed, P<sub>24</sub> becomes the OBF (Output Buffer Full) pin. A "1" written to P<sub>24</sub> enables the OBF pin (the pin outputs the OBF Status Bit). A "0" written to P<sub>24</sub> disables the OBF pin (the pin remains low). This pin can be used to indicate that valid data is available from the UPI-41A (in Output Data Bus Buffer).

If "EN FLAGS" has been executed, P<sub>25</sub> becomes the  $\overline{IBF}$  (Input Buffer Full) pin. A "1" written to P<sub>25</sub> enables the  $\overline{IBF}$  pin (the pin outputs the inverse of the IBF Status Bit). A "0" written to P<sub>25</sub> disables the  $\overline{IBF}$  pin (the pin remains low). This pin can be used to indicate that the UPI-41A is ready for data.

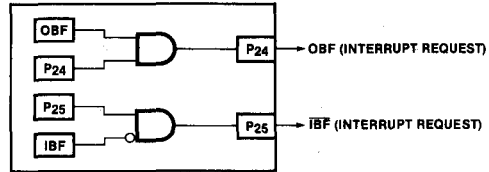

DATA BUS BUFFER INTERRUPT CAPABILITY

EN FLAGS Op Code: 0F5H

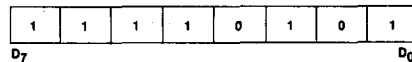

- P<sub>26</sub> and P<sub>27</sub> are port pins or DMA handshake pins for use with a DMA controller. These pins default to port pins on Reset.

If the "EN DMA" instruction has been executed, P<sub>26</sub> becomes the DRQ (DMA ReQuest) pin. A "1" written to P<sub>26</sub> causes a DMA request (DRQ is activated). DRQ is deactivated by  $\overline{DACK} \cdot \overline{RD}$ ,  $\overline{DACK} \cdot \overline{WR}$ , or execution of the "EN DMA" instruction.

If "EN DMA" has been executed, P<sub>27</sub> becomes the  $\overline{DACK}$  (DMA ACKnowledge) pin. This pin acts as a chip select input for the Data Bus Buffer registers during DMA transfers.

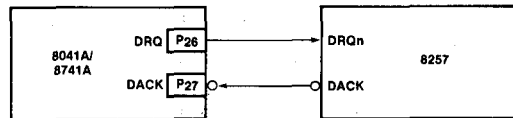

DMA HANDSHAKE CAPABILITY

EN DMA Op Code: 0E5H

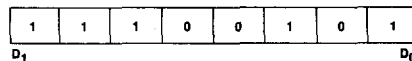

**APPLICATIONS**

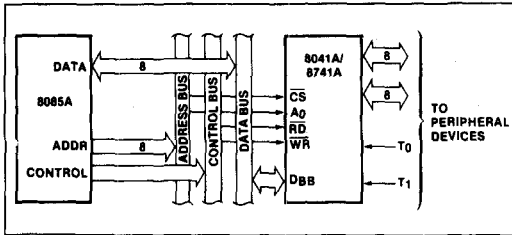

**Figure 3. 8085A-8041A Interface**

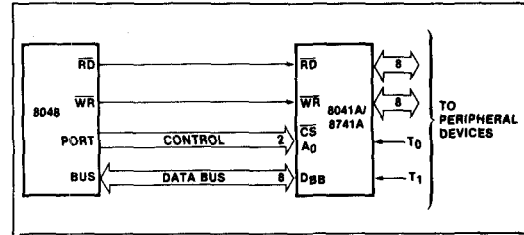

**Figure 4. 8048-8041A Interface**

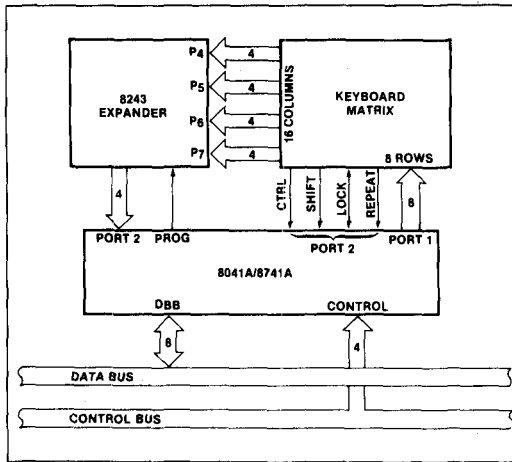

**Figure 5. 8041A-8243 Keyboard Scanner**

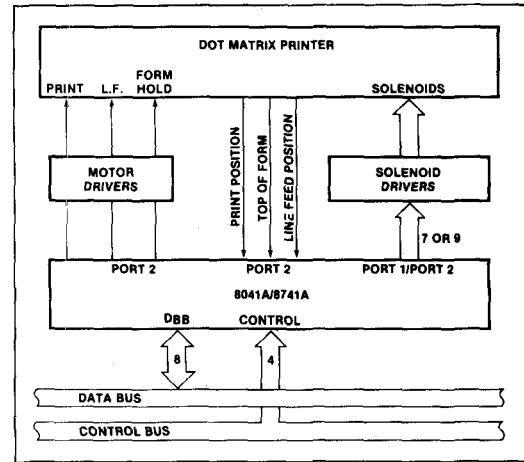

**Figure 6. 8041A Matrix Printer Interface**

**PROGRAMMING, VERIFYING, AND ERASING THE 8741A EPROM**

**Programming Verification**

In brief, the programming process consists of: activating the program mode, applying an address, latching the address, applying data, and applying a programming pulse. Each word is programmed completely before moving on to the next and is followed by a verification step. The following is a list of the pins used for programming and a description of their functions:

Pin	Function
XTAL 1	Clock Input (1 to 6MHz)
Reset	Initialization and Address Latching
Test 0	Selection of Program or Verify Mode
EA	Activation of Program/Verify Modes
BUS	Address and Data Input Data Output During Verify
P20-1	Address Input
V <sub>DD</sub>	Programming Power Supply
PROG	Program Pulse Input

**WARNING:**

An attempt to program a missocketed 8741A will result in severe damage to the part. An indication of a properly socketed part is the appearance of the SYNC clock output. The lack of this clock may be used to disable the programmer.

**The Program/Verify sequence is:**

1. A<sub>0</sub> = 0V, CS = 5V, EA = 5V, RESET = 0V, TEST0 = 5V, V<sub>DD</sub> = 5V, clock applied or internal oscillator operating, BUS and PROG floating.
2. Insert 8741A in programming socket
3. TEST 0 = 0v (select program mode)
4. EA = 23V (activate program mode)
5. Address applied to BUS and P20-1
6. RESET = 5v (latch address)
7. Data applied to BUS
8. V<sub>DD</sub> = 25v (programming power)
9. PROG = 0v followed by one 50ms pulse to 23V
10. V<sub>DD</sub> = 5v
11. TEST 0 = 5v (verify mode)

12. Read and verify data on BUS
13. TEST 0 = 0v
14. RESET = 0v and repeat from step 5
15. Programmer should be at conditions of step 1 when 8741A is removed from socket.

#### 8741A Erasure Characteristics

The erasure characteristics of the 8741A are such that erasure begins to occur when exposed to light with wavelengths shorter than approximately 4000 Angstroms (Å). It should be noted that sunlight and certain types of fluorescent lamps have wavelengths in the 3000-4000Å range. Data show that constant exposure to room level fluorescent lighting could erase the typical 8741A in approximately 3 years while it would take ap-

proximately one week to cause erasure when exposed to direct sunlight. If the 8741A is to be exposed to these types of lighting conditions for extended periods of time, opaque labels are available from Intel which should be placed over the 8741A window to prevent unintentional erasure.

The recommended erasure procedure for the 8741A is exposure to shortwave ultraviolet light which has a wavelength of 2537Å. The integrated dose (i.e., UV intensity x exposure time) for erasure should be a minimum of 15 w-sec/cm<sup>2</sup>. The erasure time with this dosage is approximately 15 to 20 minutes using an ultraviolet lamp with a 12,000 μW/cm<sup>2</sup> power rating. The 8741A should be placed within one inch of the lamp tubes during erasure. Some lamps have a filter on their tubes which should be removed before erasure.

**ABSOLUTE MAXIMUM RATINGS\***

Ambient Temperature Under Bias ..... 0°C to 70°C  
 Storage Temperature ..... - 65°C to + 150°C  
 Voltage on Any Pin With Respect  
 to Ground ..... -0.5V to +7V  
 Power Dissipation ..... 1.5 Watt

*\*NOTICE: Stresses above those listed under "Absolute Maximum Ratings" may cause permanent damage to the device. This is a stress rating only and functional operation of the device at these or any other conditions above those indicated in the operational sections of this specification is not implied. Exposure to absolute maximum rating conditions for extended periods may affect device reliability.*

**D.C. CHARACTERISTICS** ( $T_A = 0^\circ\text{C}$  to  $70^\circ\text{C}$ ,  $V_{SS} = 0\text{V}$ ; 8041A/8741A,  $V_{CC} = +5\text{V} \pm 10\%$ )

Symbol	Parameter	Min.	Max.	Unit	Test Conditions
$V_{IL}$	Input Low Voltage (Except XTAL1, XTAL2, RESET)	-0.5	0.8	V	
$V_{IL1}$	Input Low Voltage (XTAL1, XTAL2, RESET)	-0.5	0.6	V	
$V_{IH}$	Input High Voltage (Except XTAL1, XTAL2, RESET)	2.2	$V_{CC}$		
$V_{IH1}$	Input High Voltage (XTAL1, XTAL2, RESET)	3.8	$V_{CC}$	V	
$V_{OL}$	Output Low Voltage ( $D_0$ - $D_7$ )		0.45	V	$I_{OL} = 2.0\text{ mA}$
$V_{OL1}$	Output Low Voltage ( $P_{10}P_{17}$ , $P_{20}P_{27}$ , Sync)		0.45	V	$I_{OL} = 1.6\text{ mA}$
$V_{OL2}$	Output Low Voltage (Prog)		0.45	V	$I_{OL} = 1.0\text{ mA}$
$V_{OH}$	Output High Voltage ( $D_0$ - $D_7$ )	2.4		V	$I_{OH} = -400\ \mu\text{A}$
$V_{OH1}$	Output High Voltage (All Other Outputs)	2.4		V	$I_{OH} = -50\ \mu\text{A}$
$I_{IL}$	Input Leakage Current ( $T_0$ , $T_1$ , $\overline{RD}$ , $\overline{WR}$ , $\overline{CS}$ , $A_0$ , EA)		$\pm 10$	$\mu\text{A}$	$V_{SS} \leq V_{IN} \leq V_{CC}$
$I_{OZ}$	Output Leakage Current ( $D_0$ - $D_7$ , High Z State)		$\pm 10$	$\mu\text{A}$	$V_{SS} + 0.45 \leq V_{OUT} \leq V_{CC}$
$I_{LI}$	Low Input Load Current ( $P_{10}P_{17}$ , $P_{20}P_{27}$ )		0.5	mA	$V_{IL} = 0.8\text{V}$
$I_{LI1}$	Low Input Load Current ( $\overline{RESET}$ , $\overline{SS}$ )		0.2	mA	$V_{IL} = 0.8\text{V}$
$I_{DD}$	$V_{DD}$ Supply Current		15	mA	Typical=5 mA
$I_{CC} + I_{DD}$	Total Supply Current		125	mA	Typical=60 mA
$I_{IH}$	Input High Leakage Current		100	$\mu\text{A}$	$V_{IN} = V_{CC}$
$C_{IN}$	Input Capacitance		10	pF	
$C_{I/O}$	I/O Capacitance		20	pF	

**D.C. CHARACTERISTICS—PROGRAMMING** ( $T_A = 25^\circ\text{C} \pm 5^\circ\text{C}$ ,  $V_{CC} = 5\text{V} \pm 5\%$ ,  $V_{DD} = 25\text{V} \pm 1\text{V}$ )

Symbol	Parameter	Min.	Max.	Unit	Test Conditions
$V_{DOH}$	$V_{DD}$ Program Voltage High Level	24.0	26.0	V	
$V_{DDL}$	$V_{DD}$ Voltage Low Level	4.75	5.25	V	
$V_{PH}$	PROG Program Voltage High Level	21.5	24.5	V	
$V_{PL}$	PROG Voltage Low Level		0.2	V	
$V_{EAH}$	EA Program or Verify Voltage High Level	21.5	24.5	V	
$V_{EAL}$	EA Voltage Low Level		5.25	V	
$I_{DD}$	$V_{DD}$ High Voltage Supply Current		30.0	mA	
$I_{PROG}$	PROG High Voltage Supply Current		16.0	mA	
$I_{EA}$	EA High Voltage Supply Current		1.0	mA	

**A.C. CHARACTERISTICS** ( $T_A = 0^\circ\text{C}$  to  $70^\circ\text{C}$ ,  $V_{SS} = 0\text{V}$ ; 8041A/8741A,  $V_{CC} = V_{DD} = +5\text{V} \pm 10\%$ )

**DBB READ**

Symbol	Parameter	Min.	Max.	Unit	Test Conditions
$t_{AR}$	$\overline{CS}$ , $A_0$ Setup to $\overline{RD}$ ↓	0		ns	
$t_{RA}$	$\overline{CS}$ , $A_0$ Hold After $\overline{RD}$ ↓	0		ns	
$t_{RR}$	$\overline{RD}$ Pulse Width	250		ns	
$t_{AD}$	$\overline{CS}$ , $A_0$ to Data Out Delay		225	ns	$C_L = 150\text{ pF}$
$t_{RD}$	$\overline{RD}$ ↓ to Data Out Delay		225	ns	$C_L = 150\text{ pF}$
$t_{DF}$	$\overline{RD}$ ↓ to Data Float Delay		100	ns	
$t_{CY}$	Cycle Time (Except 8741A-8)	2.5	15	$\mu\text{s}$	6.0 MHz XTAL
$t_{CY}$	Cycle Time (8741A-8)	4.17	15	$\mu\text{s}$	3.6 MHz XTAL

**DBB WRITE**

Symbol	Parameter	Min.	Max.	Unit	Test Conditions
$t_{AW}$	$\overline{CS}$ , $A_0$ Setup to $\overline{WR}$ ↓	0		ns	
$t_{WA}$	$\overline{CS}$ , $A_0$ Hold After $\overline{WR}$ ↓	0		ns	
$t_{WW}$	$\overline{WR}$ Pulse Width	250		ns	
$t_{DW}$	Data Setup to $\overline{WR}$ ↓	150		ns	
$t_{WD}$	Data Hold After $\overline{WR}$ ↓	0		ns	

**A.C. CHARACTERISTICS—PROGRAMMING** ( $T_A = 25^\circ\text{C} \pm 5^\circ\text{C}$ ,  $V_{CC} = 5\text{V} \pm 5\%$ ,  $V_{DD} = 25\text{V} \pm 1\text{V}$ )

Symbol	Parameter	Min.	Max.	Unit	Test Conditions
$t_{AW}$	Address Setup Time to $\overline{\text{RESET}}$ ↓	4tcy			
$t_{WA}$	Address Hold Time After $\overline{\text{RESET}}$ ↓	4tcy			
$t_{DW}$	Data in Setup Time to PROG ↓	4tcy			
$t_{WD}$	Data in Hold Time After PROG ↓	4tcy			
$t_{PH}$	$\overline{\text{RESET}}$ Hold Time to Verify	4tcy			
$t_{VDDW}$	$V_{DD}$ Setup Time to PROG ↓	4tcy			
$t_{VDDH}$	$V_{DD}$ Hold Time After PROG ↓	0			
$t_{PW}$	Program Pulse Width	50	60	mS	
$t_{TW}$	Test 0 Setup Time for Program Mode	4tcy			
$t_{WT}$	Test 0 Hold Time After Program Mode	4tcy			
$t_{DO}$	Test 0 to Data Out Delay		4tcy		
$t_{WW}$	$\overline{\text{RESET}}$ Pulse Width to Latch Address	4tcy			
$t_r, t_f$	$V_{DD}$ and PROG Rise and Fall Times	0.5	2.0	$\mu\text{s}$	
$t_{CY}$	CPU Operation Cycle Time	5.0		$\mu\text{s}$	
$t_{RE}$	$\overline{\text{RESET}}$ Setup Time Before EA ↓.	4tcy			

Note: If TEST 0 is high,  $t_{DO}$  can be triggered by  $\overline{\text{RESET}}$  ↓.

**A.C. CHARACTERISTICS—DMA**

Symbol	Parameter	Min.	Max.	Unit	Test Conditions
$t_{ACC}$	$\overline{\text{DACK}}$ to $\overline{\text{WR}}$ or $\overline{\text{RD}}$	0		ns	
$t_{CAC}$	$\overline{\text{RD}}$ or $\overline{\text{WR}}$ to $\overline{\text{DACK}}$	0		ns	
$t_{ACD}$	$\overline{\text{DACK}}$ to Data Valid		225	ns	$C_L = 150\text{ pF}$
$t_{CRQ}$	$\overline{\text{RD}}$ or $\overline{\text{WR}}$ to DRQ Cleared		200	ns	

**A.C. CHARACTERISTICS—PORT 2** ( $T_A = 0^\circ\text{C}$  to  $70^\circ\text{C}$ : 8041A/8741A,  $V_{CC} = +5\text{V} \pm 10\%$ )

Symbol	Parameter	Min.	Max.	Unit	Test Conditions
t <sub>CP</sub>	Port Control Setup Before Falling Edge of PROG	110		ns	C <sub>L</sub> = 80 pF
t <sub>PC</sub>	Port Control Hold After Falling Edge of PROG	100		ns	C <sub>L</sub> = 20 pF
t <sub>PR</sub>	PROG to Time P2 Input Must Be Valid		810	ns	C <sub>L</sub> = 80 pF
t <sub>PF</sub>	Input Data Hold Time	0	150	ns	C <sub>L</sub> = 20 pF
t <sub>DP</sub>	Output Data Setup Time	250		ns	C <sub>L</sub> = 80 pF
t <sub>PD</sub>	Output Data Hold Time	65		ns	C <sub>L</sub> = 20 pF
t <sub>PP</sub>	PROG Pulse Width	1200		ns	

**TYPICAL 8041/8741A CURRENT**

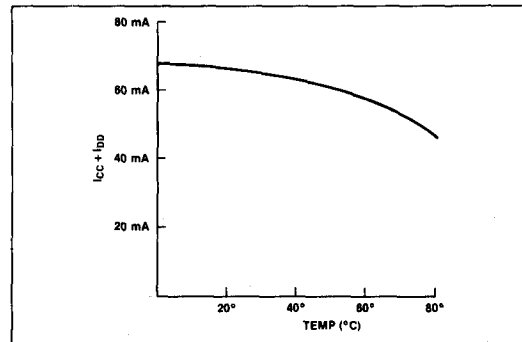

**CRYSTAL OSCILLATOR MODE**

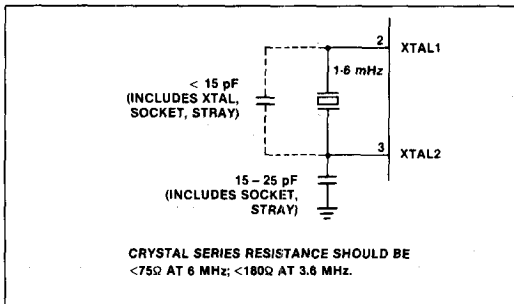

**DRIVING FROM EXTERNAL SOURCE**

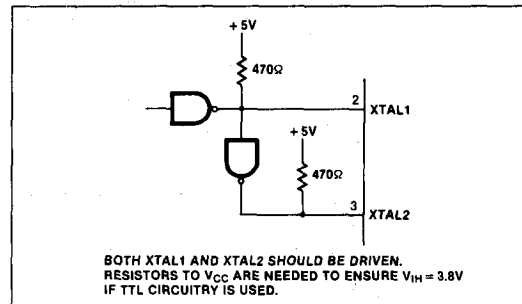

**LC OSCILLATOR MODE**

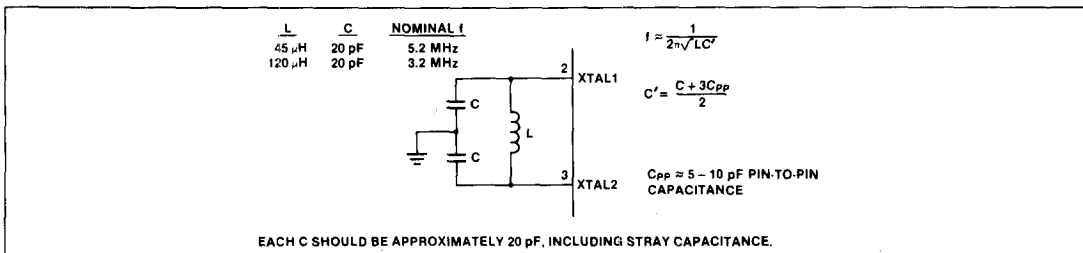



WAVEFORMS

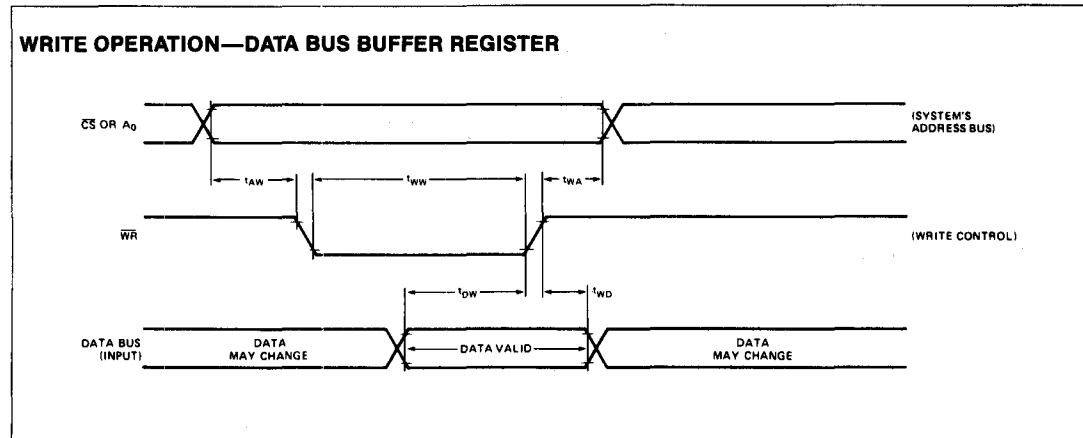
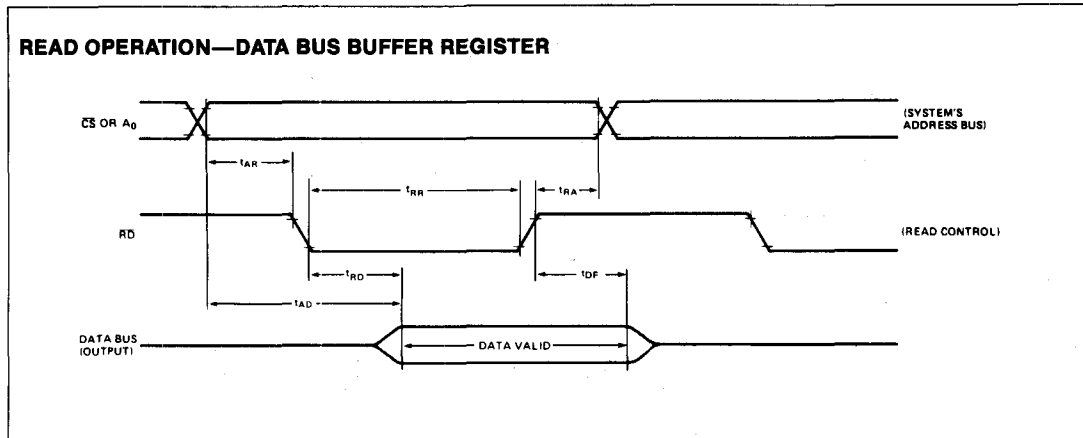

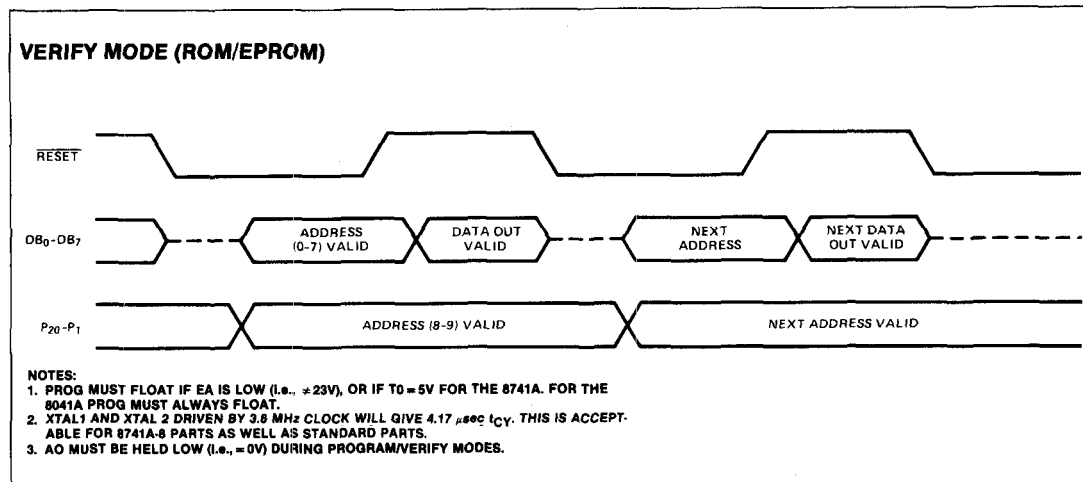
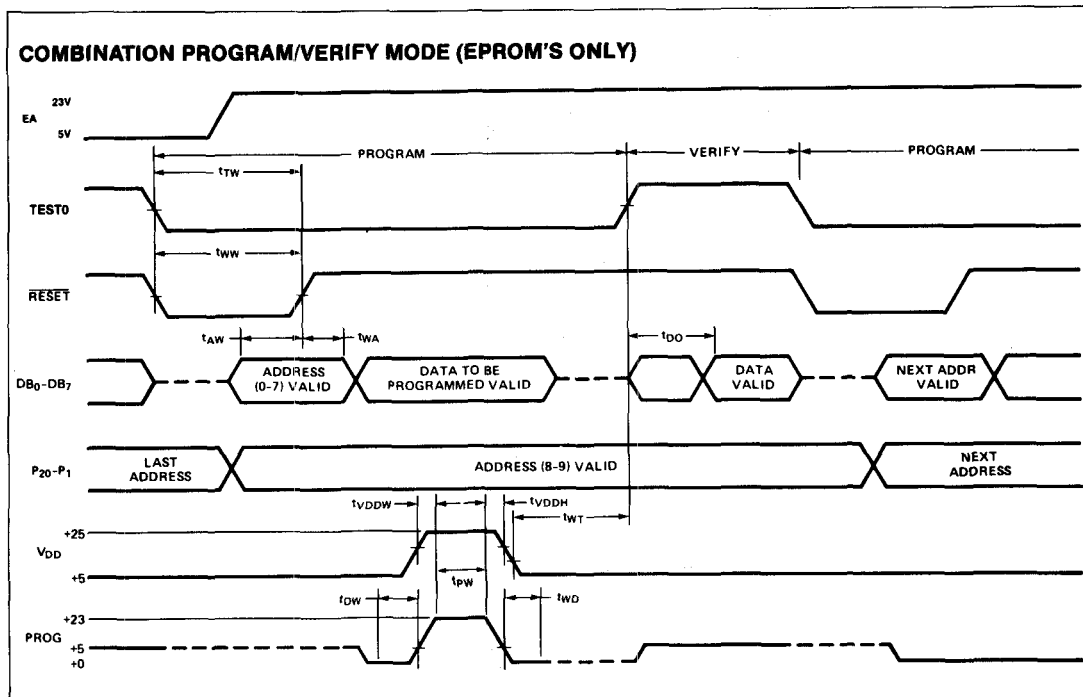
**WAVEFORMS (Continued)**

The 8741A EPROM can be programmed by either of two Intel products:

1. PROMPT-48 Microcomputer Design Aid, or
2. Universal PROM Programmer (UPP series) peripheral of the Intellect<sup>®</sup> Development System with a UPP-848 Personality Card.

WAVEFORMS (Continued)

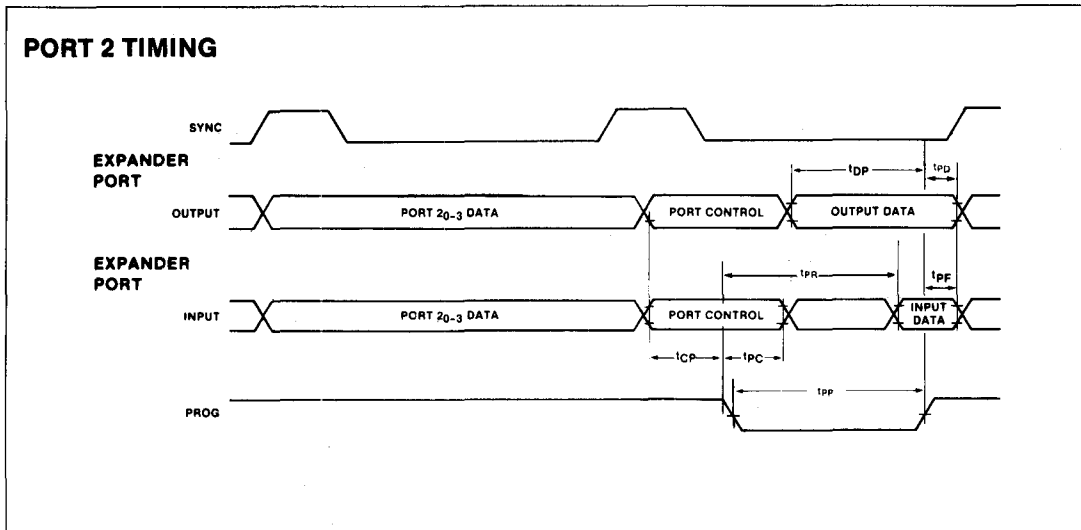
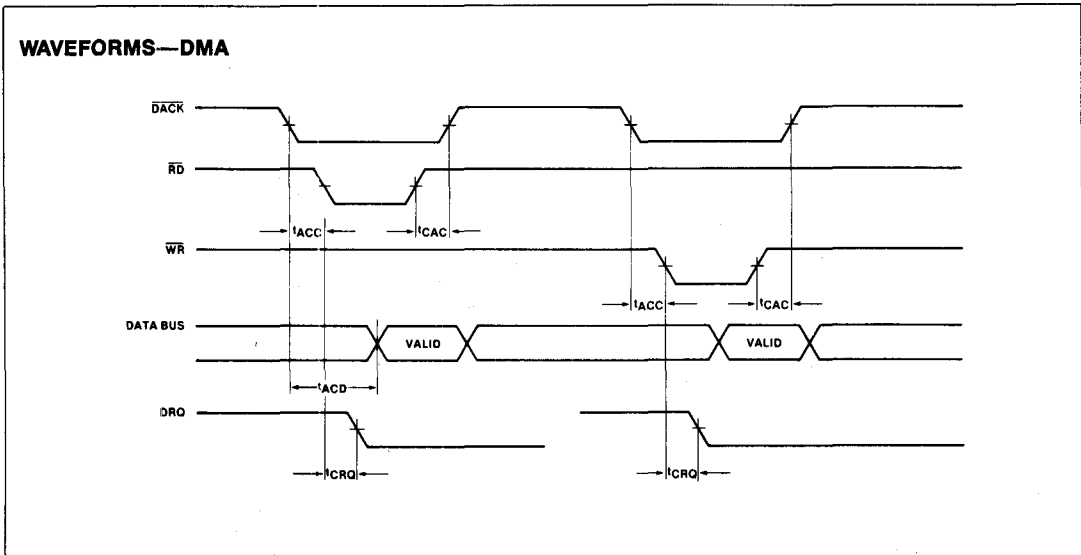

Table 2. UPI™ Instruction Set

Mnemonic	Description	Bytes	Cycles
<b>ACCUMULATOR</b>			
ADD A, Rr	Add register to A	1	1
ADD A, @Rr	Add data memory to A	1	1
ADD A, #data	Add immediate to A	2	2
ADDC A, Rr	Add register to A with carry	1	1
ADDC A, @Rr	Add data memory to A with carry	1	1
ADDC A, #data	Add immediate to A with carry	2	2
ANL A, Rr	AND register to A	1	1
ANL A, @Rr	AND data memory to A	1	1
ANL A, #data	AND immediate to A	2	2
ORL A, Rr	OR register to A	1	1
ORL A, @Rr	OR data memory to A	1	1
ORL A, #data	OR immediate to A	2	2
XRL A, Rr	Exclusive OR register to A	1	1
XRL A, @Rr	Exclusive OR data memory to A	1	1
XRL A, #data	Exclusive OR immediate to A	2	2
INC A	Increment A	1	1
DEC A	Decrement A	1	1
CLR A	Clear A	1	1
CPL A	Complement A	1	1
DA A	Decimal Adjust A	1	1
SWAP A	Swap nibbles of A	1	1
RL A	Rotate A left	1	1
RLC A	Rotate A left through carry	1	1
RR A	Rotate A right	1	1
RRC A	Rotate A right through carry	1	1
<b>INPUT/OUTPUT</b>			
IN A, Pp	Input port to A	1	2
OUTL Pp, A	Output A to port	1	2
ANL Pp, #data	AND immediate to port	2	2
ORL Pp, #data	OR immediate to port	2	2
IN A, DBB	Input DBB to A, clear IBF	1	1
OUT DBB, A	Output A to DBB, set OBF	1	1
MOV STS, A	A <sub>4</sub> -A <sub>7</sub> to Bits 4-7 of Status	1	1
MOVD A, Pp	Input Expander port to A	1	2
MOVD Pp, A	Output A to Expander port	1	2
ANLD Pp, A	AND A to Expander port	1	2
ORLD Pp, A	OR A to Expander port	1	2

Mnemonic	Description	Bytes	Cycles
<b>DATA MOVES</b>			
MOV A, Rr	Move register to A	1	1
MOV A, @Rr	Move data memory to A	1	1
MOV A, #data	Move immediate to A	2	2
MOV Rr, A	Move A to register	1	1
MOV @Rr, A	Move A to data memory	1	1
MOV Rr, #data	Move immediate to register	2	2
MOV @Rr, #data	Move immediate to data memory	2	2
MOV A, PSW	Move PSW to A	1	1
MOV PSW, A	Move A to PSW	1	1
XCH A, Rr	Exchange A and register	1	1
XCH A, @Rr	Exchange A and data memory	1	1
XCHD A, @Rr	Exchange digit of A and register	1	1
MOVP A, @A	Move to A from current page	1	2
MOVP3, A, @A	Move to A from page 3	1	2
<b>TIMER/COUNTER</b>			
MOV A, T	Read Timer/Counter	1	1
MOV T, A	Load Timer/Counter	1	1
STRT T	Start Timer	1	1
STRT CNT	start Counter	1	1
STOP TCNT	Stop Timer/Counter	1	1
EN TCNTI	Enable Timer/Counter Interrupt	1	1
DIS TCNTI	Disable Timer/Counter Interrupt	1	1
<b>CONTROL</b>			
EN DMA	Enable DMA Handshake Lines	1	1
EN I	Enable IBF Interrupt	1	1
DIS I	Disable IBF Interrupt	1	1
EN FLAGS	Enable Master Interrupts	1	1
SEL RB0	Select register bank 0	1	1
SEL RB1	Select register bank 1	1	1
NOF	No Operation	1	1
<b>REGISTERS</b>			
INC Rr	Increment register	1	1
INC @Rr	Increment data memory	1	1
DEC Rr	Decrement register	1	1
<b>SUBROUTINE</b>			
CALL addr	Jump to subroutine	2	2
RET	Return	1	2
RETR	Return and restore status	1	2

**Table 2. UPI™ Instruction Set (Continued)**

Mnemonic	Description	Bytes	Cycles
<b>FLAGS</b>			
CLR C	Clear Carry	1	1
CPL C	Complement Carry	1	1
CLR F0	Clear Flag 0	1	1
CPL F0	Complement Flag 0	1	1
CLR F1	Clear F1 Flag	1	1
CPL F1	Complement F1 Flag	1	1
<b>BRANCH</b>			
JMP addr	Jump unconditional	2	2
JMPP @A	Jump indirect	1	2
DJNZ Rr, addr	Decrement register and jump	2	2
JC addr	Jump on Carry=1	2	2
JNC addr	Jump on Carry=0	2	2
JZ addr	Jump on A Zero	2	2
JNZ addr	Jump on A not Zero	2	2
JT0 addr	Jump on T0=1	2	2
JNT0 addr	Jump on T0=0	2	2
JT1 addr	Jump on T1=1	2	2
JNT1 addr	Jump on T1=0	2	2
JF0 addr	Jump on F0 Flag=1	2	2
JF1 addr	Jump on F1 Flag=1	2	2
JTF addr	Jump on Timer Flag =1, Clear Flag	2	2
JNIBF addr	Jump on IBF Flag =0	2	2
JOBF addr	Jump on OBF Flag =1	2	2
JBb addr	Jump on Accumulator Bit	2	2